

Specifications

Number of Cylinders 6
 Bore and Stroke . . . 5½ in. x 6 in.
 Piston Displacement . . . 855 cu. in.
 Operating Cycles 4
 Lube System Oil Cap. . . 8 U.S. gals.
 Engine Coolant Cap. . . 9.5 U.S. gals.
 Net Weight with Std.
 Accessories, Dry 3150 lbs.

Specific ratings are shown on rear page.

Metric

6
 140 x 152mm
 14 l
 4
 30.3 l
 36 l
 1 429 kg

Design Features

Bearings: Precision type, steel backed inserts. 7 main bearings, 4½ in. (114mm) diameter. Connecting Rod – 3⅞ in. (79mm) diameter.

Camshaft: Single camshaft controls all valve and injector movement. Induction hardened alloy steel with gear drive.

Camshaft Followers: Roller type for long cam and follower life.

Connecting Rods: Drop forged, 12 in. (305mm) center to center length. Rifle drilled for pressure lubrication of piston pin. Taper piston pin end reduces unit pressures.

Cooler, Lubricating Oil: Tubular type, jacket water cooled.

Crankshaft: High tensile strength steel forging. Bearing journals are induction hardened. Fully counterweighted.

Cylinder Block: Alloy cast iron with removable, wet liners.

Cylinder Heads: Each head serves two cylinders. Drilled fuel supply and return lines. Corrosion resistant inserts on intake and exhaust valve seats.

Fuel System: Cummins PT™ Fuel system with integral, flyball type, variable speed governor. Camshaft actuated injectors.

Gear Train: Heavy duty, located at front of cylinder block.

Lubrication: Force feed to all bearings, gear type pump. All lubrication lines are drilled passages, except pan to pump suction line.

Pistons: Aluminum, cam ground. Oil cooled.

Piston Pins: 2 in. (51mm) diameter, full floating.

Turbocharger: Cummins, T-50, top mounted.

Valves: Dual intake and exhaust each cylinder. Each valve 1⅞ in. (47mm) diameter. Heat and corrosion resistant face on exhaust valve.



Listed under Underwriters' Laboratories, Inc., reexamination service for fire protection applications.

Listed by Associated Factory Mutual Fire Insurance Companies for fire protection applications.

Listed under Underwriters' Laboratories of Canada label service for fire protection applications.

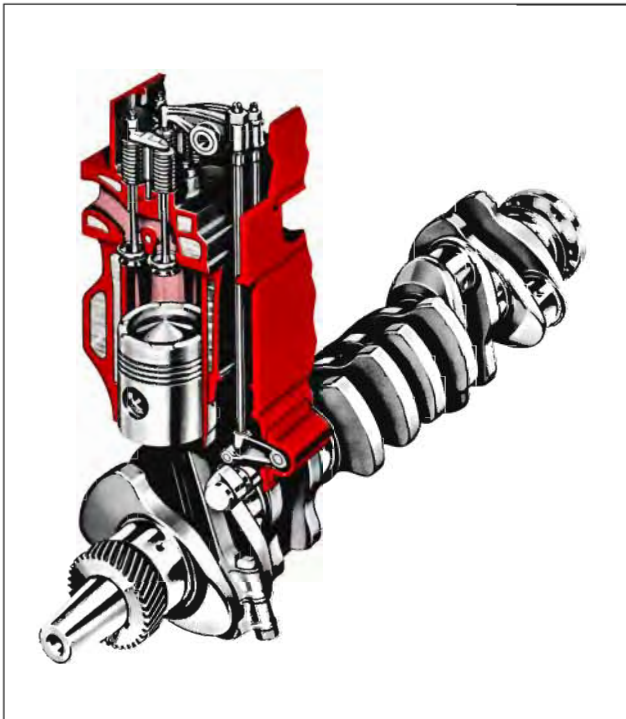

Big Displacement Design Features

- 1 **Internal Fuel Lines:** Drilled passages in cylinder heads eliminate threaded fuel line connectors and external lines.
- 2 **Large Intake and Exhaust Passages:** Minimize restriction of air and exhaust flow. Allows maximum air charge for clean burning, top economy.
- 3 **Overhead Valves:** Precision machined from high strength alloy steel. Intake valves are of silichrome steel. Exhaust valves of big displacement models are nitrogen steel for high temperature strength and faced with corrosion resistant material.
- 4 **Open Type Combustion Chamber:** Gives most efficient combustion . . . most power from each gallon of fuel.
- 5 **Replaceable Wet-type Cylinder Liners:** Dissipate heat faster. Liners are easily replaced without re boring block.
- 6 **Conventional Push Rod and Rocker Lever Arrangement:** Activates valves and injectors from a single camshaft. Roller type camshaft followers are used for long life.
- 7 **Cam-ground Pistons:** Assure perfect fit at operating temperatures.
- 8 **Alloy Cast Iron Cylinder Block:** Follows proven design and material specification to achieve maximum durability.
- 9 **Large Volume Water Passages:** Give even flow of coolant around cylinder liners, valves, and injectors to draw excess heat from combustion chamber. Centrifugal pump circulates large volumes of water.
- 10 **Connecting Rods:** Forged from high tensile strength alloy steel. I-beam section gives maximum strength. Large diameter piston pins are full-floating. Tapered piston pin end used for superior load distribution and maximum crown material on piston.
- 11 **Counterweighted Crankshafts:** Precision machined from high tensile strength steel forgings. Bearing journals are induction hardened for long life.

LISTED AGENCY RATINGS

Underwriters' Laboratories:

255 HP @ 1750 RPM
 255 HP @ 1900 RPM
 255 HP @ 2100 RPM

Factory Mutual:

255 HP @ 1750 RPM
 255 HP @ 1900 RPM
 255 HP @ 2100 RPM

Underwriters' Laboratories of Canada:

255 HP @ 1750 RPM
 255 HP @ 1900 RPM
 255 HP @ 2100 RPM

The agency-approved horsepower ratings shown are already derated for fire pump service and available for driving the fire pump at sea level altitude (29.92 in. Hg and 60°F. intake air temperature). The only additional deration necessary is for higher ambient temperatures and elevations as follows: 3% for each 1000 feet above sea level and 1% for each 10 degrees above 60°F. in accordance with National Fire Protection Association Pamphlet No. 20.

Installation Considerations

Maximum raw water pressure must not exceed 65 PSI. Minimum acceptable raw water flow at 90°F. raw water temperature and 100°F. ambient air temperature should be at least 34 G.P.M. at the 2100 RPM listed rating.

Ventilation air required for engine combustion is 760 CFM at 2100 RPM rating. This is for engine air combustion only and does not take into consideration additional air required for normal room cooling.

Cummins has always been a pioneer in product improvement. Thus specifications may change without notice. Illustrations may include optional equipment.

Cummins Engine Company, Inc., Columbus, Indiana 47201

Standard Equipment

Air Cleaner: 16 in. (406 mm) diameter, oil bath type, mounted.

Belt and Damper Shield Guard: Protection from alternator, accessory drive, and water pump belts and vibration damper.

Coolant Pump: Belt driven, centrifugal type.

Corrosion Resistor: Mounted, checks rust and corrosion, controls acidity, and removes impurities from coolant.

Electrical Equipment: 24 volt negative ground system. 24 volt starting motor; 24 volt, 20 ampere alternator; voltage regulator; manually operable contactors; junction box with enclosed terminal strip.

Engine Support: Pedestal type, front and rear.

Exhaust Manifold: Water cooled.

Exhaust Outlet: 5 in. (127 mm) diameter, 90° elbow.

Filters: Lubricating oil, full flow replaceable paper element, mounted. Fuel, paper element throwaway type, mounted.

Flywheel: Machined for stub shaft mounting.

Flywheel Housing: SAE No. 1 with industrial supports.

Governor: Mechanical flyball, mechanical variable speed type.

Heat Exchanger: Tubular type, mounted.

Instrument Panel: Mounted. Includes ammeter, combination tachometer and hourmeter, water temperature gauge, lubricating oil pressure gauge.

Lubricating Oil Cooler: Tubular type, jacket water cooled.

Oil Pan: Cast aluminum, rear sump type, 7 U.S. gallon (26.5 liter) capacity. Optional provision for oil heater.

Oil Pressure Switch: Provides signal to activate alarm (not included) for low oil pressure.

Overspeed Switch: Mounted, overspeed shutdown with manual reset, stop crank contacts.

Stubshaft: Mounted on flywheel.

Throttle Control: Hydraulic type with vernier override.

Vibration Damper: Viscous type.

Water Jacket Heater: Mounts under oil pan. 115 volt, 2500 watt.

Water Temperature Switch: Provides signal to activate alarm (not included) for high water temperature.

Optional Equipment

Heat Exchanger: Copper-nickel tube bundle for salt water or corrosive water cooling systems.

Left Hand Rotation: Counterclockwise rotation when viewing engine from front end.

Oil Heater: Mounted in side of oil pan.

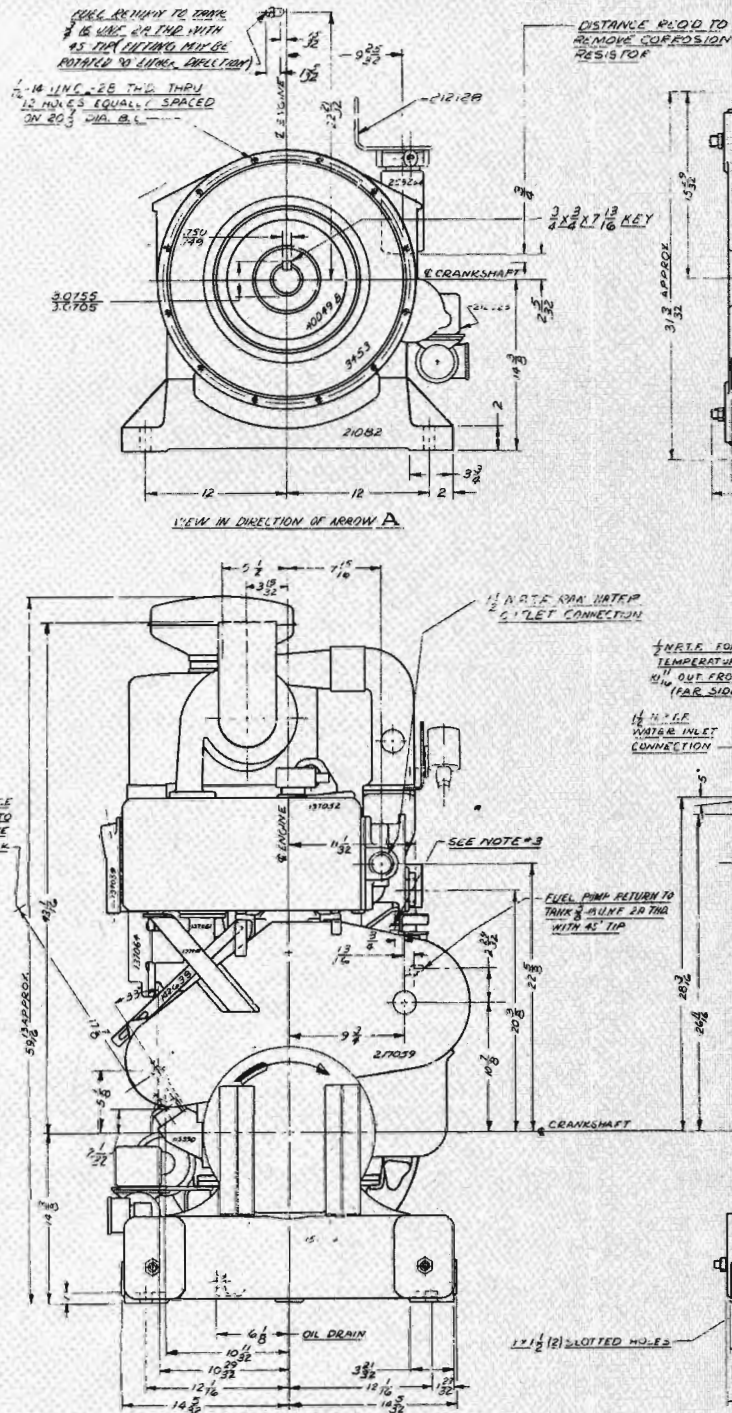

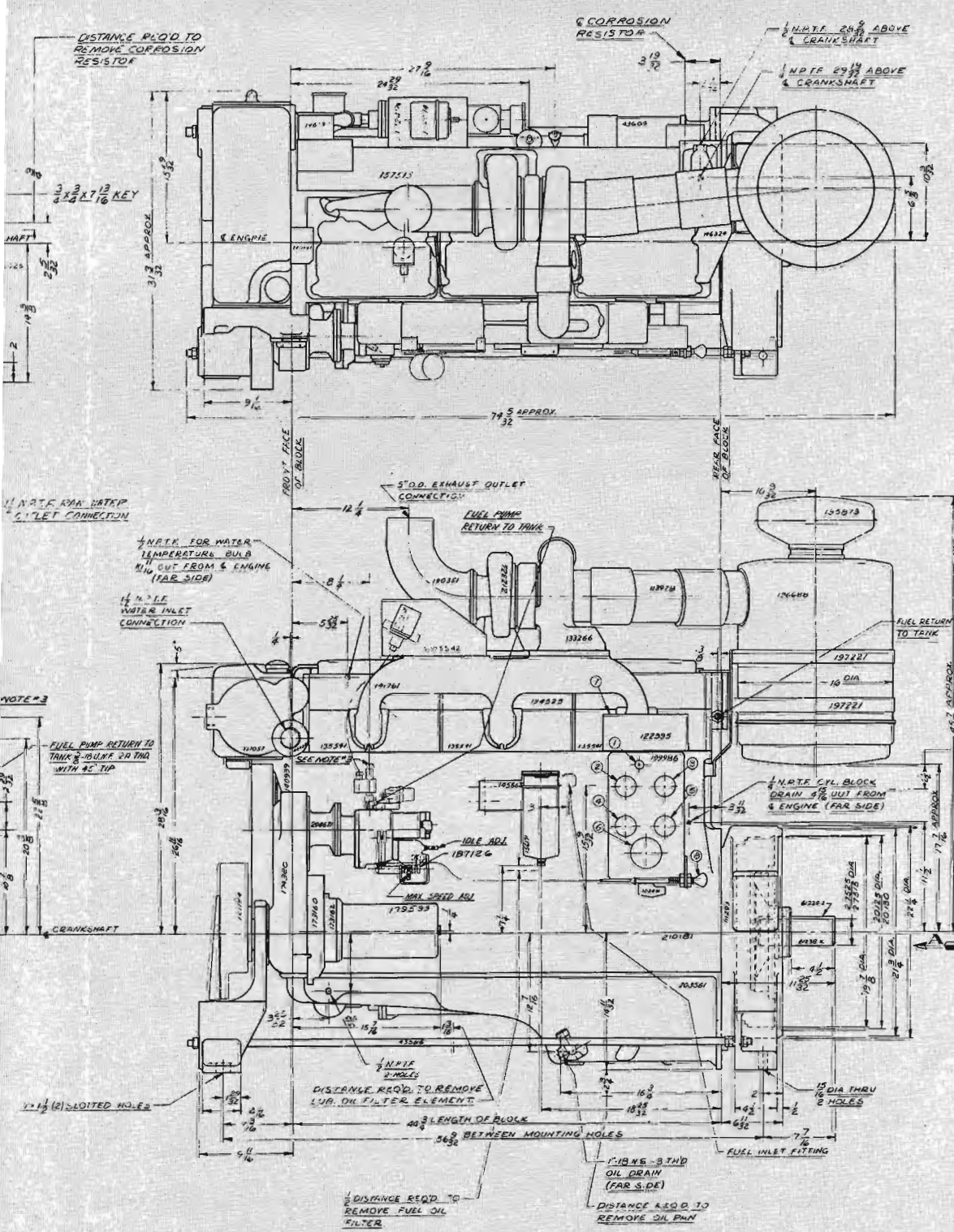

ITEM NO	COMPONENT PARTS LIST
1	CIRCUIT BREAKER
2	GAGE, WATER TEMPERATURE
3	AMMETER
4	GAGE, LUB. OIL PRESSURE
5	COVER, BLANK
6	TACHOMETER-HOURLMETER
7	BOX, JUNCTION
8	THROTTLE CONTROL

NOTE #1
TACHOMETER TAKE OFF STD. SAE 5/8" 18 M.S. THD. ACCOMMODATES 187 DRIVE TIP & ENGINE SPEED IN CLOCKWISE DIRECTION WHEN VIEWED FROM ABOVE.

NOTE #2
MAXIMUM ANNUAL OPERATION WITH THE OIL AT THE 10% LEVEL OF 5 GALLONS FOR THIS ENGINE IS 12" FRONT END OF ENGINE UP; 25" EXHAUST SIDE DOWN; 25" FUEL PUMP SIDE DOWN.

NOTE #3
A MINIMUM OF TWELVE INCHES OF FLEXIBLE CONNECTION OR TWO BALL JOINTS WITHIN THE FIRST FOUR FEET OF EXHAUST PIPE IS CONSIDERED MANDATORY FOR TURBOCHARGED ENGINES. NO MORE THAN FOUR FEET OF UNSUPPORTED EXHAUST PIPE OR FLEXIBLE CONNECTION MAY BE ATTACHED TO THE TURBOCHARGER.

NOTE #4
DISTANCE REQ'D TO REMOVE AIR CLEANER ELEMENT

NOTE #5
DISTANCE REQ'D TO REMOVE LUB. OIL FILTER ELEMENT

NOTE #6
DISTANCE REQ'D TO REMOVE FUEL OIL FILTER

NOTE #7
1" 18 M.S. 3 THD OIL DRAIN (FAR S. DE)

NOTE #8
DISTANCE REQ'D TO REMOVE OIL PAN

CUMMINS ENGINE COMPANY, INC.

Engine Data Sheet

Fire Pump Engine Model: NT-855-F1
(for listed/approved ratings see tabulation)

Date: June, 1980

Data Sheet: DS-3550-A

General Engine Data

Type:	4 Cycle;In-Line;6 Cylinder
Aspiration:	Turbocharged
Bore — in. (mm)	5.5 (140)
Stroke — in. (mm)	6 (152)
Displacement — in. ³ (litre)	855 (14)
Compression Ratio:	14.1:1
Valves per Cylinder: — Intake	2
— Exhaust	2
Engine Weight & Center of Gravity (With Standard Accessories)	
Reference Installation Diagram	208359
Dry Weight — lb. (kg)	3150 (1 429)
Wet Weight — lb. (kg)	3234 (1 467)
C.G. Distance From F.F.O.B. — in. (mm)	n.a.
C.G. Distance Above Crankshaft — in. (mm)	n.a.
Maximum Allowable Bending Moment @ Rear Face of Block — lb.-ft. (N*m)	1000 (1350)

Air Induction System

Maximum Allowable Temperature Rise Between Ambient Air and Engine Air Inlet (Ambients 32°F [0°C] to 100°F [38°C]) — °F (°C)	30 (15)
Maximum Allowable Intake Restriction With a Dirty Air Filter Element — in. H ₂ O (mm H ₂ O)	n.a.
Part Number of Standard Air Filter Element (Dry Type)	oil bath cleaner

Lubrication System

Oil Pressure @ Rated Speeds — PSI (kPa)	50—70 (340—480)
Oil Flow @ Maximum Rated Speeds (Nominal) — U.S. GPM (litre/s)	40 (2.5)
Oil Pan Capacity (High — Low) U.S. gal. (litre)	7—4 (26.5—15.0)
Full Flow Lube Oil Filter Capacity — U.S. gal. (litre)	8 (30.0)
Part Number of Standard Oil Pan	203561
Part Number of Standard Oil Filter Element	LF-516

Application Note: When ambient temperatures will be lower than 70°F (21°C) an oil heater is required. The recommended heater wattage for this engine is 300 down to 40°F (4°C).

Cooling System

Heat Exchanger Cooled (Shell & Tube Type)	
Part Number of Tube Bundle	n.a.
Raw Water Working Pressure Range at Heat Exchanger — PSI (kPa)	65 (450) Max.
Recommended Minimum Water Supply Pipe Size to	
Heat Exchanger (Reference Only) — in. (mm) dia.	1.25 (30)
Recommended Minimum Water Discharge Pipe Size From	
Heat Exchanger (Reference Only) — in. (mm) dia.	1.5 (40)
Coolant Water Capacity (Engine Side) — U.S. gal. (litre)	10 (38)
Standard Thermostat — Type	Modulating
— Range — °F (°C)	170—185 (77—85)
Minimum Raw Water Flow with Water	
Temperatures to 90°F (32°C) — U.S. GPM (litre/s)	34 (2.1)

Note: Minimum raw water requirement is based on water flow required to minimize tube fouling in the heat exchanger tube bundle.

A jacket water heater is mandatory on this engine. The recommended heater wattage is 2500 down to 40°F (4°C).

CUMMINS ENGINE COMPANY, INC.

Engine Data Sheet

Fire Pump Engine Model: NT-855-F1
(for listed/approved ratings see tabulation)

Date: June, 1980

Data Sheet: DS-3550-A

General Engine Data

Type:	4 Cycle; In-Line; 6 Cylinder
Aspiration:	Turbocharged
Bore — in. (mm)	5.5 (140)
Stroke — in. (mm)	6 (152)
Displacement — in. ³ (litre)	855 (14)
Compression Ratio:	14.1:1
Valves per Cylinder: — Intake	2
— Exhaust	2
Engine Weight & Center of Gravity (With Standard Accessories)	
Reference Installation Diagram	208359
Dry Weight — lb. (kg)	3150 (1 429)
Wet Weight — lb. (kg)	3234 (1 467)
C.G. Distance From F.F.O.B. — in. (mm)	n.a.
C.G. Distance Above \odot Crankshaft — in. (mm)	n.a.
Maximum Allowable Bending Moment @ Rear Face of Block — lb.-ft. (N•m)	1000 (1350)

Air Induction System

Maximum Allowable Temperature Rise Between Ambient Air and Engine Air Inlet (Ambients 32°F [0°C] to 100°F [38°C]) — °F (°C)	30 (15)
Maximum Allowable Intake Restriction With a Dirty Air Filter Element — in. H ₂ O (mm H ₂ O)	n.a.
Part Number of Standard Air Filter Element (Dry Type)	oil bath cleaner

Lubrication System

Oil Pressure @ Rated Speeds — PSI (kPa)	50-70 (340-480)
Oil Flow @ Maximum Rated Speeds (Nominal) — U.S. GPM (litre/s)	40 (2.5)
Oil Pan Capacity (High — Low) U.S. gal. (litre)	7-4 (26.5-15.0)
Full Flow Lube Oil Filter Capacity — U.S. gal. (litre)	8 (30.0)
Part Number of Standard Oil Pan	203561
Part Number of Standard Oil Filter Element	LF-516

Application Note: When ambient temperatures will be lower than 70°F (21°C) an oil heater is required. The recommended heater wattage for this engine is 300 down to 40°F (4°C).

Cooling System

Heat Exchanger Cooled (Shell & Tube Type)	
Part Number of Tube Bundle	n.a.
Raw Water Working Pressure Range at Heat Exchanger — PSI (kPa)	65 (450) Max.
Recommended Minimum Water Supply Pipe Size to Heat Exchanger (Reference Only) — in. (mm) dia.	1.25 (30)
Recommended Minimum Water Discharge Pipe Size From Heat Exchanger (Reference Only) — in. (mm) dia.	1.5 (40)
Coolant Water Capacity (Engine Side) — U.S. gal. (litre)	10 (38)
Standard Thermostat — Type	Modulating
— Range — °F (°C)	170-185 (77-85)
Minimum Raw Water Flow with Water Temperatures to 90°F (32°C) — U.S. GPM (litre/s)	34 (2.1)

Note: Minimum raw water requirement is based on water flow required to minimize tube fouling in the heat exchanger tube bundle.

A jacket water heater is mandatory on this engine. The recommended heater wattage is 2500 down to 40°F (4°C).

Exhaust System

Maximum Allowable Back Pressure Imposed by Piping & Silencer — in. Hg (mm Hg)	3 (75)
Exhaust Pipe Size Normally Acceptable — in. (mm) dia.	5 (125)

Fuel System

Supply Line Size — in. (mm)	0.625 (16) O.D. Tube
Drain Line Size — in. (mm)	0.625 (16) O.D. Tube
Maximum Fuel Line Length Between Supply Tank & Fuel Pump — ft. (m)	40 (12)
Maximum Fuel Height Above Crankshaft — in. (mm)	80 (2030)
Part Number of Standard Fuel Filter	156171
Part Number of Standard Fuel Filter Element	FF-105-D
Maximum Allowable Restriction to Fuel Pump With Dirty Filter — in. Hg (mm Hg)	8 (200)
Maximum Allowable Return Line Restriction — in. Hg (mmHg)	4 (100)

Electrical System

Battery Voltage	24	
Battery Cable Size (Maximum Cable Length Not to Exceed 10 ft. (3.0 m) AWG)	00	
Wiring for Automatic Starting (Negative Ground)	Standard	
Alternator (Standard) 24 Volt, Internally Regulated — Ampere		
Manually Operable Contactors	Standard	
Minimum Recommended Battery Capacity —	<u>Amp-hr.</u>	<u>°F CCA</u>
70 °F (21 °C) Minimum Temperature	100	450
32 °F (0 °C) Minimum Temperature	150	640
Reference Wiring Diagram Number	212461	

Performance Data

All data is based on the engine operating with fuel system, water pump, lubricating oil pump, air cleaner, and alternator; not included are compressor, fan, optional equipment and driven components. Data is based on operation at SAE standard J816b conditions of 500 feet (150 m) altitude (29.00 in. [736 mm] Hg dry barometer), 85 °F (29 °C) intake air temperature and 0.38 in. (9.6 mm) Hg water vapor pressure, using No. 2 diesel or a fuel corresponding to ASTM D2. All data is subject to change without notice.

Altitude Above Which Output Should be Limited — ft. (m)	500' (150m)
Correction Factor per 1000 ft. (300 m) above Altitude Limit	3%
Temperature Above Which Output Should be Limited — °F (°C)	85 (29)
Correction Factor per 10 °F (11 °C) Above Temperature Limit	1% (2%)

Listed/Approved Ratings BHP (kW)	Speed RPM	Ventilation Air Req'd. For Combustion CFM (litre/s)	Heat Rejection to Cooling Water BTU/min. (kW)	Heat Rejection to Ambient Air* BTU/min. (kW)	Exhaust Gas Flow CFM (litre/s)	Exhaust Gas Temp. °F (°C)	Fuel Consumption gal./hr. (litre/h)
UL LISTED RATINGS							
259 (193)	2100	798 (377)	10,500 (184)	1209 (21.2)	1496 (706)	620 (334)	14.0 (53.0)
259 (193)	1900	693 (328)	10,080 (176)	1140 (20.0)	1344 (634)	656 (353)	13.2 (50.0)
259 (193)	1750	593 (280)	9,870 (173)	1140 (20.0)	1197 (565)	704 (379)	13.2 (50.0)
FM APPROVED RATINGS							
245 (183)	2100	760 (359)	10,000 (176)	900 (15.8)	1425 (673)	590 (310)	14.0 (53.0)
245 (183)	1900	660 (312)	9,600 (169)	900 (15.8)	1280 (604)	625 (329)	13.2 (50.0)
245 (183)	1750	565 (267)	9,400 (165)	900 (15.8)	1140 (538)	670 (354)	13.2 (50.0)

*Does not include exhaust piping.

Fire Pump Engine Model: NT-855-F1
 Data Sheet No.: DS-3550-A
 Date: June, 1980
 Bulletin No.: 3383354